

RDF locating transmitter and Receiver

Having seen many a rocket lost I decided the best way to ensure that I would have least chance in loosing a rocket was to buy or make a tracking transmitter and receiver, I first looked for one to purchase and found they were very expensive, the next option was to make one. I found that Programming by Pete had a few ideas and designs on RDF, I adopted one of his designs, that was to use a Radiometrix or Linx module for the transmitter and receiver. I looked at the Radiometrix web site www.radiometrix.com and found the two modules I needed. I rang radiometrix and ordered my TXM and RXm on 418MHz (Radio operators License not required in the UK).

Locating Transmitter

I ordered the pic, battery, coax and diode from maplins (part list below). The next task was to program the PIC luckily a work colleague had a PIC Programmer that he purchased from www.K009.Demon.co.uk and was very cheap but worked fine (except it does not verify 12c508's&9's. Having got the PIC programmed I assembled the TX as shown in the diagram below. The PIC was hot melt glued to the back of the TXM and its legs cut short, all wires were then soldered directly to the shortened legs. The legs on the TXM were removed and wires joined to the pads where the legs were.

Parts list

- 1 x TXM-418-A from RadioMetrix
- 1 x PIC12C508 from Farnell Part number 140-193 @ £1.13
- 1 x Coax for Antenna from Maplins Part number XS83E @ £1.49/Meter

Locating Receiver

I ordered the parts from maplins and Farnell (part lists below). And set about planning where all the bits were to be positioned The RX is quite different to the one pictured in the Programming by Pete web site due to using a different module, this RXM module has the Signal Strength output, this is useful in RDF so I implemented a circuit to take full advantage of this, The Squelch feature works but not brilliantly, but not bad for a first attempt! Having assembled the circuit on a PCB I etched (Once again using the etching kit mentioned in location beeper section) I use a 9v battery and have added a voltage regulator (not shown) as the housing I am using has a compartment for a pp3.

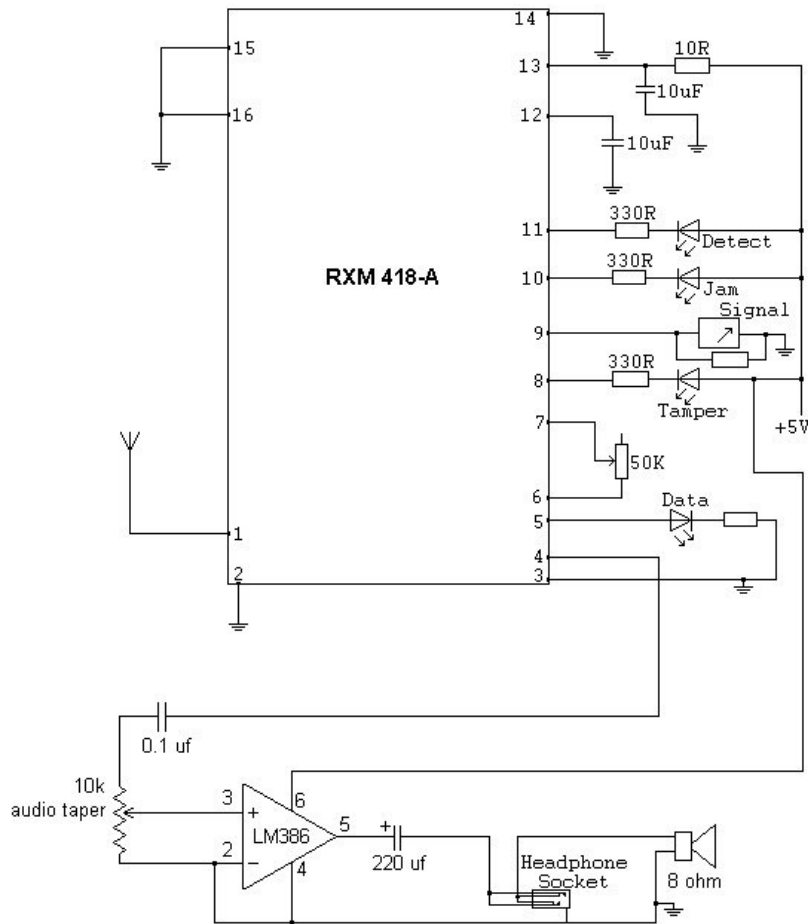

Click to enlarge

Parts List

- 1 x Box from Farnell Part Number 736-363 @ £8.11
- 1 x RXM-418-A from RadioMetrix
- 1 x 10 ohm Resistor
- 3 x 330 ohm Resistor
- 1 x 50K ohm Variable Resistor from Maplin Part Number
- 1 x 10K ohm Variable Resistor from Maplin Part Number VQ08J @ £2.19
- 1 x Signal Meter from Maplin Part Number LB80B @ £3.99
- 1 x 675 ohm Resistor
- 4 x LED's
- 2 x Tantalum 10µF capacitor from Maplin Part Number WW68Y @ £0.78
- 1 x Ceramic Disk 0.1µF capacitor from Maplin Part Number YR75S @ £0.19
- 1 x 220µF capacitor from Maplin Part Number TY95D @ £0.20
- 1 x Head Phone Socket from Maplin Part Number JM20W @ £0.45

- 1 x 8 ohm Speaker from Maplin Part Number VC84F @ £1.99
- 1 x LM386 from Maplin part Number ARC40 @ £1.06
- 1 x 5v Regulator LP2950CZ50 from Farnell Part Number 412-478 @ £1.82
- 1 x BNC Socket from Maplin Part Number DV28F @ £2.10

Yagi Antenna

The Yagi from Programming modified to 418MHz. Instead of using a wooded beam for the mount I used an aluminium square section tube as this will not have the moisture problems of wood. I drilled the holes for the elements slightly over size to allow for insulation tape around the elements so as to insulate them from the Aluminium. Each element was then epoxied in place.

The Elements are 1/8" brass rod (purchased from local non ferrous metal dealer for £4.00)

The handle is a bicycle handle, to make this fit a few pieces of wood were glued to the aluminium section to increase the diameter to fit the handle.

The Aluminium was 1/2" square section aluminium (form the same non ferrous metal dealer for £3.50)

Co-Ax cable is RG58 approx 1.5M long with a BNC connector on the end to join to RX. I drilled a hole in the aluminium section between the handle and the reflector element so as to thread the coax from the end of the handle through the Aluminium cross section and out of the hole to solder it on to the driven element. (Maplin Part Number XS66W @£1.29/meter)

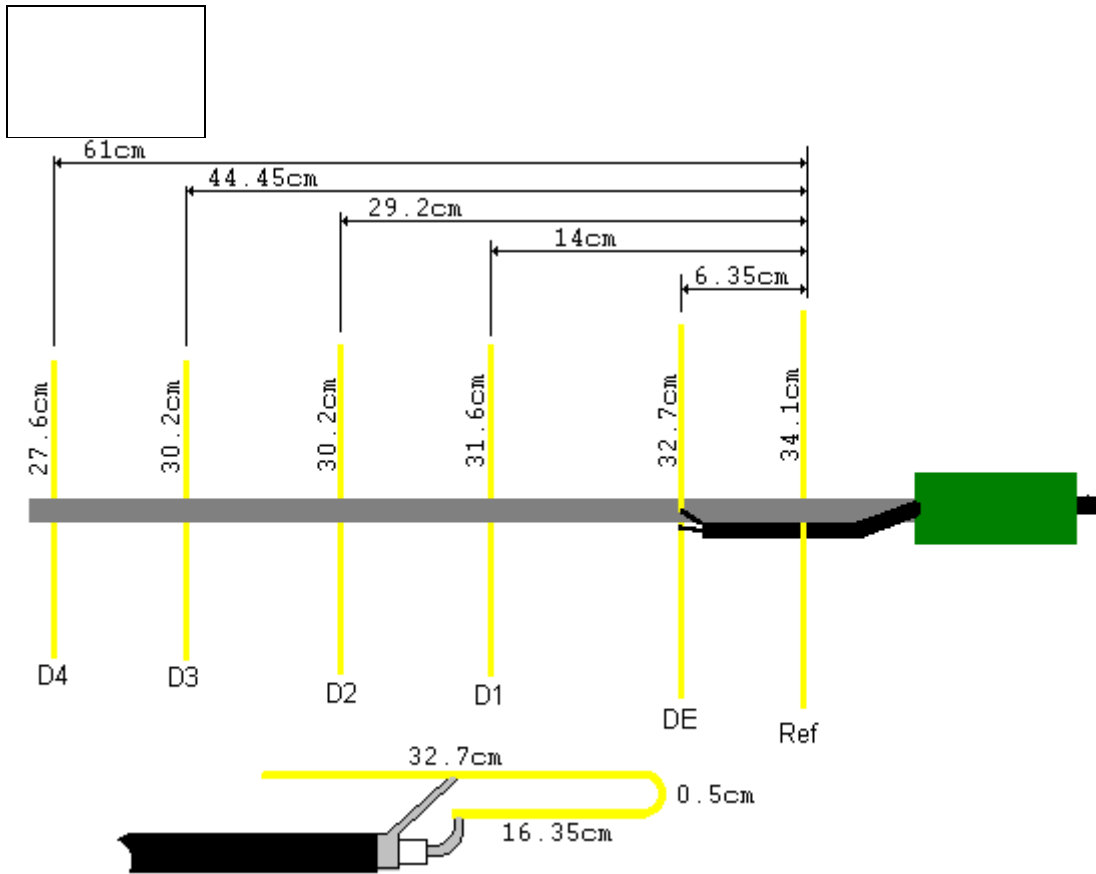

Click to enlarge

Element lengths given in order from tip director element first in order toward handle:

first director- 10-7/8"

2nd & 3rd directors- 11-7/8"

4th director- 12-7/16"

driven element- measured to outside of radius-- 12-7/8"

reflector-- 13-7/16"

RDF Results

The RDF system described above was tested along a country lane, the TX was set on the ground at the side of a long straight road, I then Drove down the road until I could no longer detect the signal using the RX, Walking back towards the RX pointing the antenna to where I knew the TX to be I started to pick up the signal at 0.6Mile. I have also tested this using a Yupiteru MVT7100 scanner and the results with that were surprisingly slightly less.